

ELECTRICAL SCHEMATIC LAYOUT

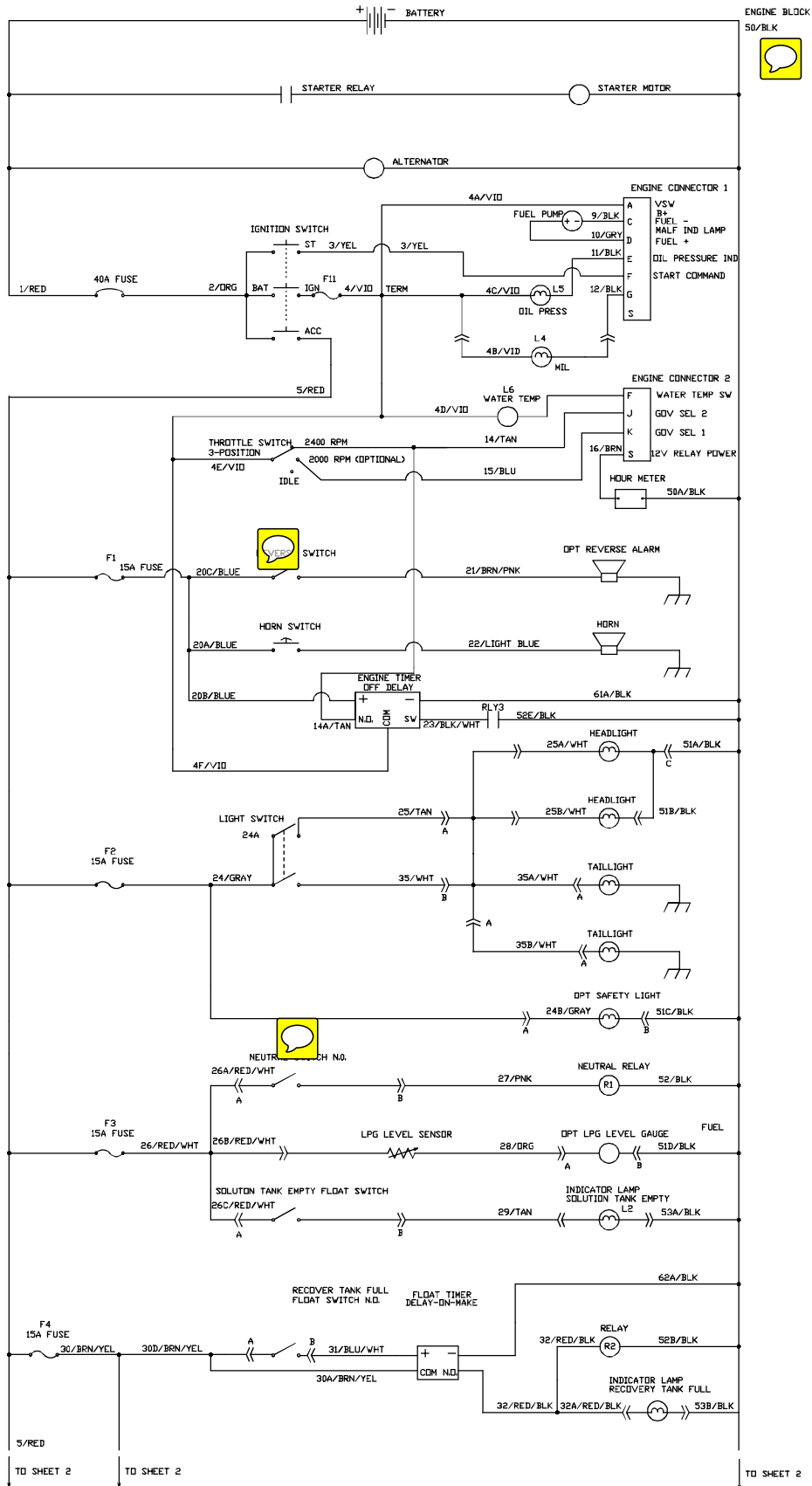

745925-1, REV *
12/20/2013

ELECTRICAL SCHEMATIC LAYOUT

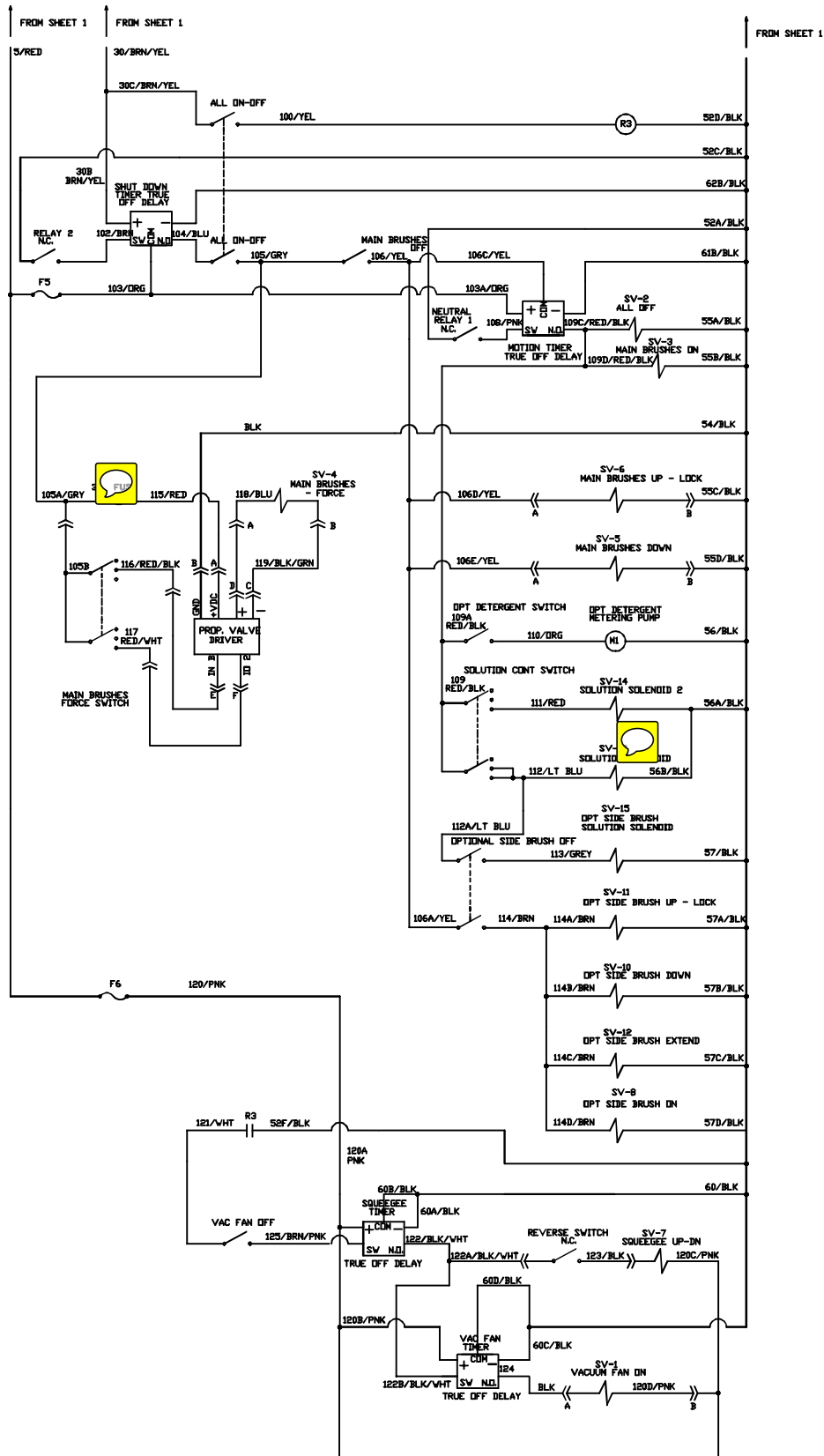

745925-2, REV *
12/20/2013